

SHP650 Series



- Rugged Industrial Construction
- Top Fan & 'U' Channel Options
- -20 °C to +70 °C Operation
- 5 V Standby
- AC OK, Remote On/Off and Active Current Share
- Screw Terminals
- 3 Year Warranty

Specification

Input

Input Voltage	• 85-264 VAC, derate output power 10% <90 VAC
Input Frequency	• 47-63 Hz
Input Current	• 6.5 A at 115 VAC typical • 3.2 A at 230 VAC with 650 W load
Inrush Current	• 40 A max at 264 VAC
Power Factor	• EN61000-3-2 class A compliant
Earth Leakage Current	• 0.75 mA max 264 VAC 60 Hz
Input Protection	• T 16 A / 250 V internal in line fuse

Output

Output Voltage	• 12-48 VDC (see tables)
Output Voltage Trim	• $\pm 10\%$ V1
Initial Set Accuracy	• $\pm 1\%$ V1, $\pm 5\%$ V3
Minimum Load	• No minimum load required
Start Up Delay	• 500 ms max
Start Up Rise Time	• 50 ms
Hold Up Time	• 20 ms minimum
Drift	• $\pm 0.2\%$ after 20 min warm up
Line Regulation	• $\pm 0.5\%$ maximum
Load Regulation	• $\pm 1\%$ V1, $\pm 5\%$ V3
Transient Response	• 4% max. deviation, recovery to within 1% in 500 μ s for a 50-75-50% load change
Ripple & Noise	• 1% pk-pk V1, 20 MHz bandwidth
Overvoltage Protection	• 115-145% Vnom, recycle input to reset
Overtemperature Protection	• Auto reset
Overload Protection	• 110-140%, V1 only
Short Circuit Protection	• Auto recovery
Temperature Coefficient	• 0.05% / °C
Remote Sense	• Compensates for 0.5 V total voltage drop
Remote On/Off	• Uncommitted isolated optocoupler diode, powered diode inhibits V1 & V2 fan supply
Current Share	• Single wire current share

General

Efficiency	• 86% typical
Isolation	• 3000 VAC input to output, 1500 VAC input to ground, 500 VDC output to ground
Switching Frequency	• PFC 70 KHz, main converter 200 KHz typical
Power Density	• 8.2 W/in ³
Signals	• AC OK, remote on/off, current share
MTBF	• 300 KHrs to MIL-HDBK-217F at 25 °C, GB

Environmental

Operating Temperature	• -20 °C to +70 °C, derate linearly from +50 °C at 2.5% / °C to 50% load at +70 °C
Cooling	• Forced cooled, '-TF' & '-EF' models have integral dual voltage level fan, which is load dependant, U Channel requires 5.5 m/s minimum airflow
Operating Humidity	• 95% RH, non-condensing
Storage Temperature	• -40 °C to +85 °C
Operating Altitude	• 3000 m
Shock	• 30 g pk, half sine, 6 axes
Vibration	• 2 g rms, 5 Hz to 500 kHz, 3 axes

EMC & Safety

Emissions	• EN55022 level B conducted • EN55022 level A radiated
Harmonic Currents	• EN61000-3-2, class A
Voltage Flicker	• EN61000-3-3
Radiated Immunity	• EN61000-4-3, level 3 Perf Criteria A
EFT/Burst	• EN61000-4-4, level 3 Perf Criteria A
Surge	• EN61000-4-5, installation class 3, Perf Criteria A
Conducted Immunity	• EN61000-4-6, level 3, Perf Criteria A
Dips & Interruptions	• EN61000-4-11, 30% 10 ms, 60% 100 ms, 100% 5000 ms, Perf Criteria A, B, B
Safety Approvals	• IEC60950-1 CB report, CSA 22.2 No. 60950-1, UL60950-1, TUV, EN60950-1

Models and Ratings

Output Voltage V1	Max Output Current V1	Fan Supply V2 ⁽⁴⁾	Standby Supply V3	Max Output Power ⁽³⁾	Model Number ^(1,2)
12 V	50.0 A	12 V / 0.5 A	5 V / 0.2 A	607 W	SHP650PS12-EF
15 V	40.0 A	12 V / 0.5 A	5 V / 0.2 A	607 W	SHP650PS15-EF
24 V	27.0 A	12 V / 0.5 A	5 V / 0.2 A	657 W	SHP650PS24-EF
28 V	23.0 A	12 V / 0.5 A	5 V / 0.2 A	651 W	SHP650PS28-EF
36 V	18.0 A	12 V / 0.5 A	5 V / 0.2 A	657 W	SHP650PS36-EF
48 V	13.5 A	12 V / 0.5 A	5 V / 0.2 A	657 W	SHP650PS48-EF

Notes

1. For top fan version replace '-EF' in model number with '-TF'.
2. For U Channel version remove suffix.
3. U Channel models require a minimum of 5.5 m/s airflow from the system.
4. Not available for '-TF' and '-EF' models as used by integral fan.

Mechanical Details

End Fan

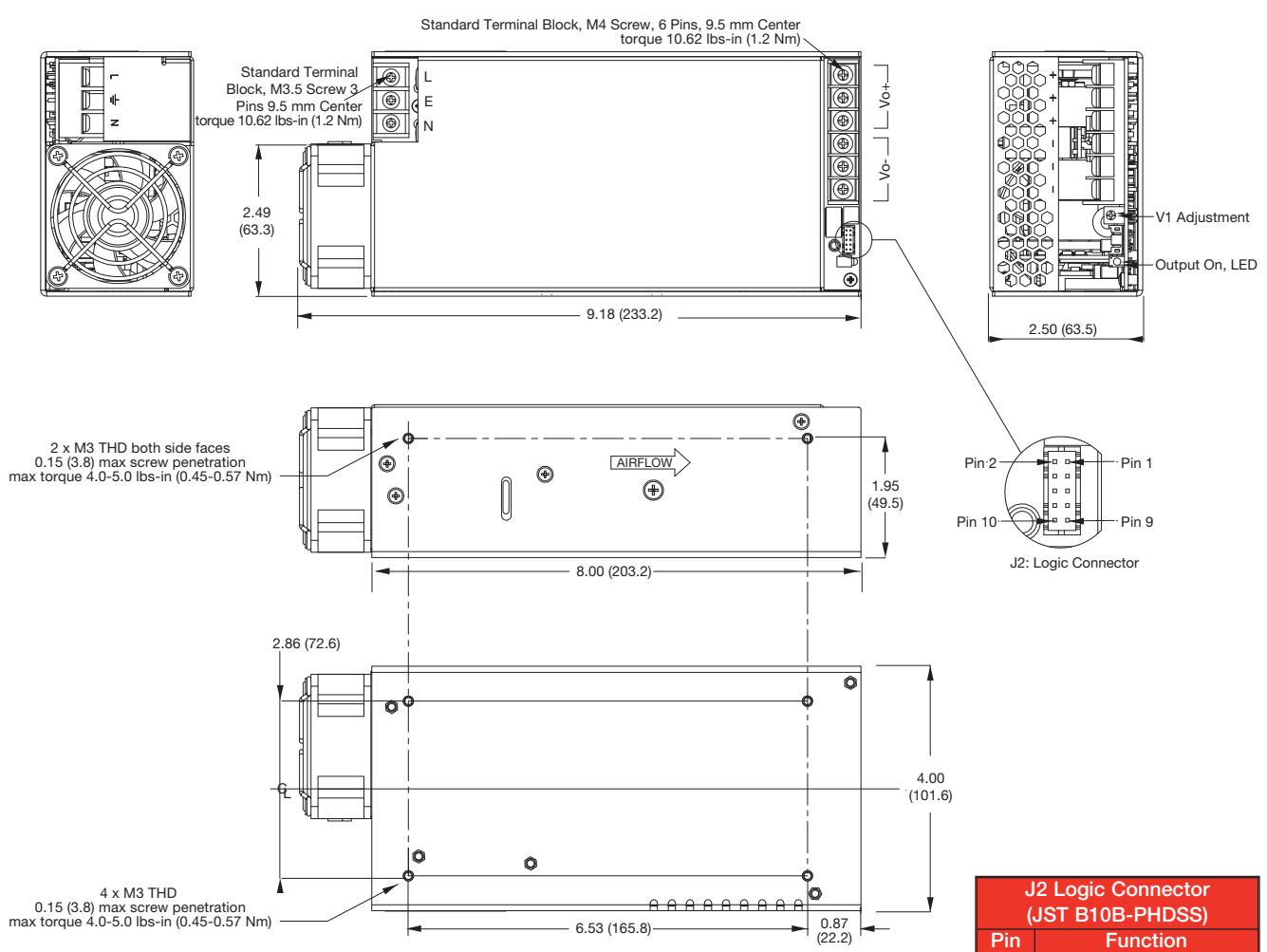

J2 Logic Connector (JST B10B-PHDSS)	
Pin	Function
1	+ Sense
2	- Sense
3	AC OK/Power Fail
4	- Sense
5	Current Share
6	Current Share
7	+ Inhibit
8	- Inhibit
9	+5 V Standby (V3)
10	5 V Standby Return (V3)

Notes

1. Dimensions shown in inches (mm).
2. Weight: 2.8 lb (1.25 kg).
3. J2 Mating plug: JST part no. PHDR-10VS, contact: 26-22 AWG JST part no. SPHD-001T-P0.5.

Mechanical Details

Top Fan (Suffix - TF)

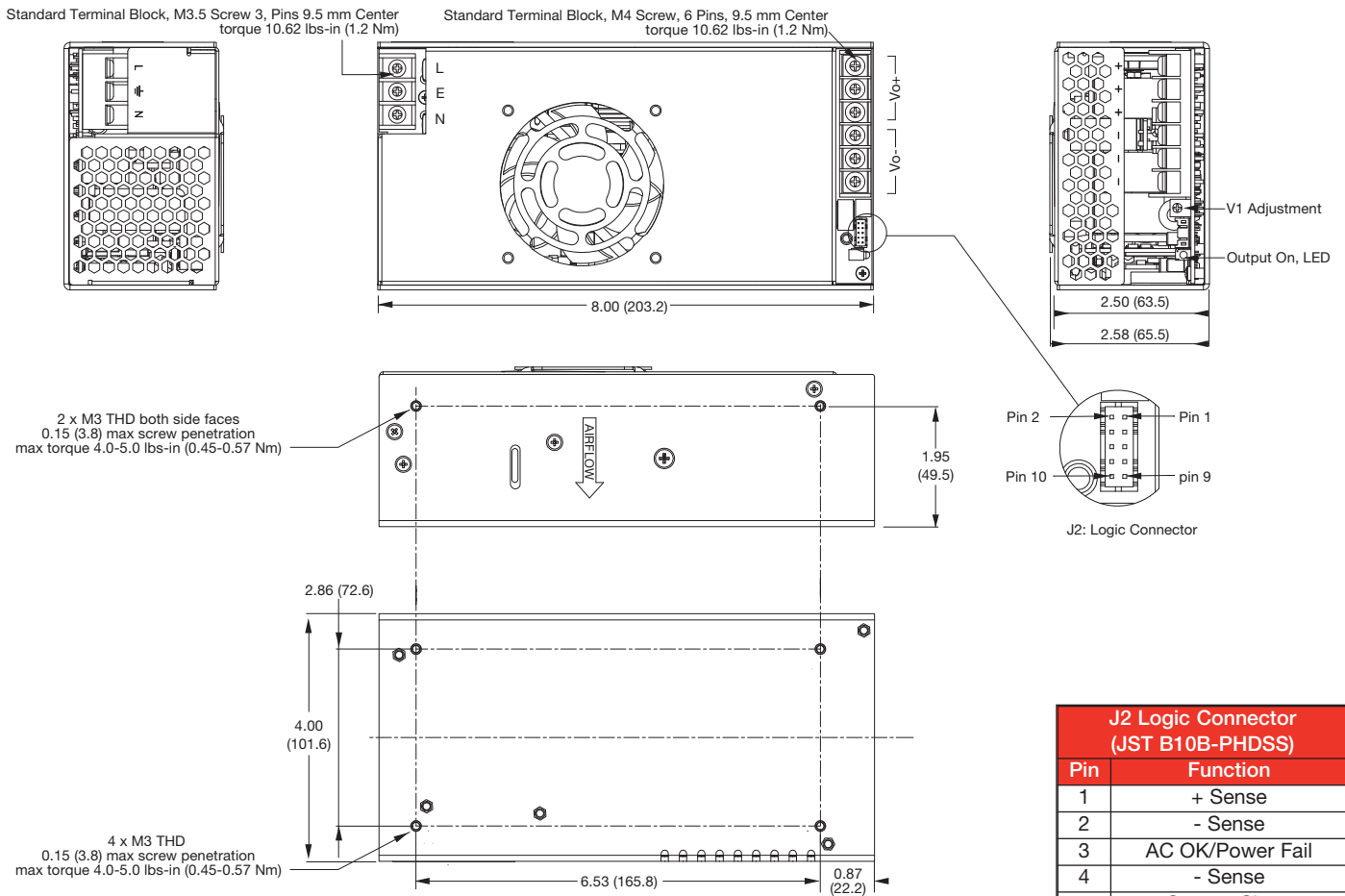

J2 Logic Connector (JST B10B-PHDSS)	
Pin	Function
1	+ Sense
2	- Sense
3	AC OK/Power Fail
4	- Sense
5	Current Share
6	Current Share
7	+ Inhibit
8	- Inhibit
9	+5 V Standby (V3)
10	5 V Standby Return (V3)

Notes

- Dimensions shown in inches (mm).
- Weight: 2.6 lb (1.2 kg).
- J2 Mating plug: JST part no. PHDR-10VS, contact: 26-22 AWG JST part no. SPHD-001T-P0.5.

Signals

AC OK/Power Fail

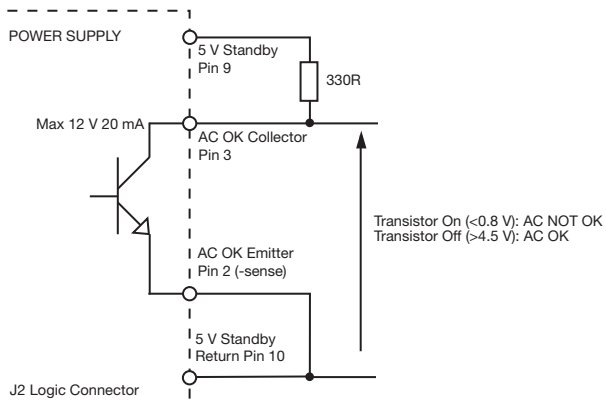

Remote On/Off (Inhibit)

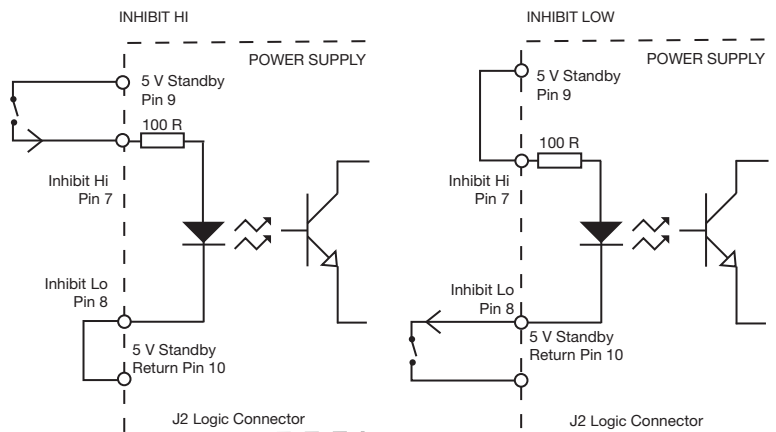

Mechanical Details

U Channel (No Suffix)

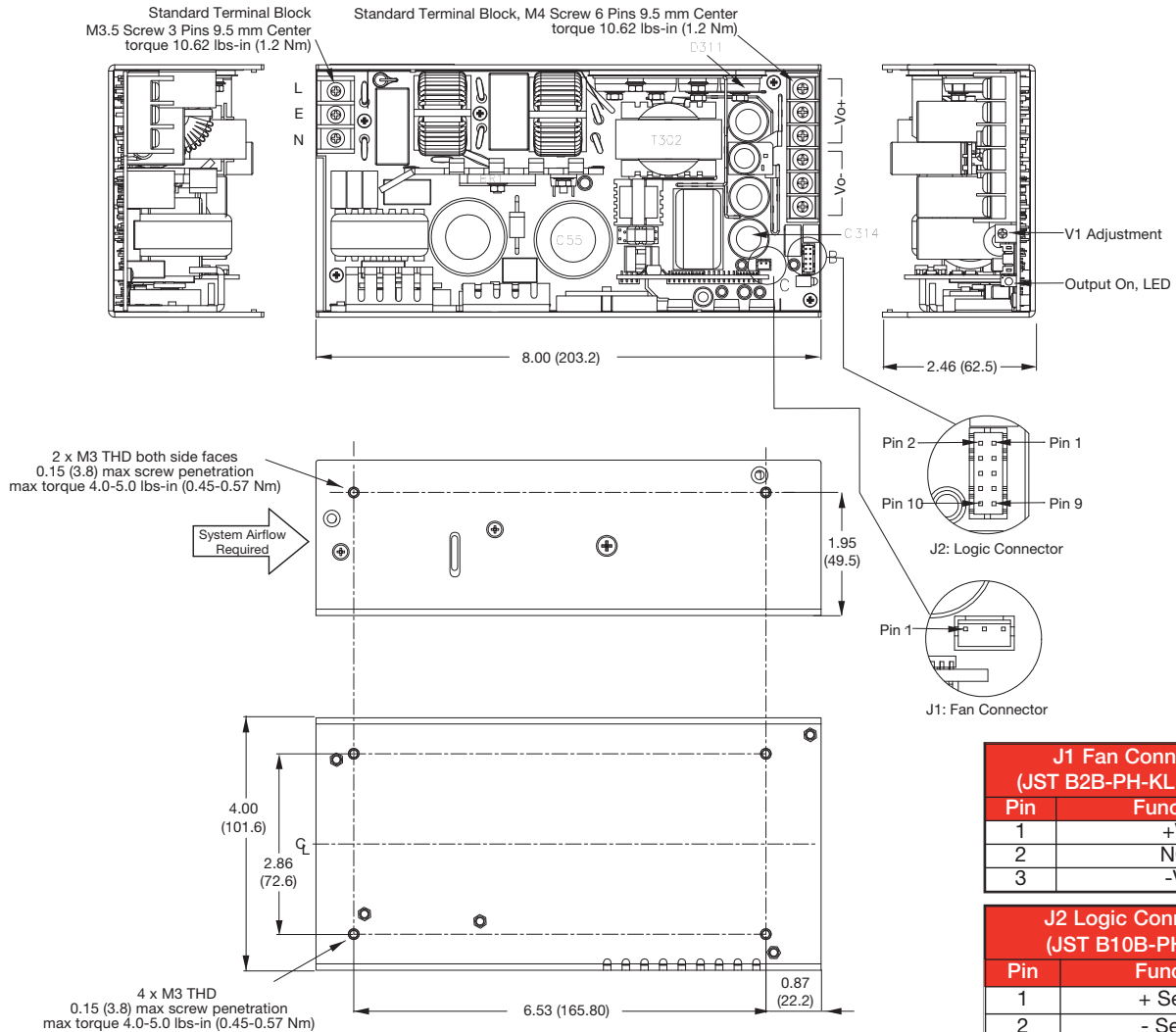

Notes

1. Dimensions shown in inches (mm).
2. Weight: 2.4 lb (1.1 kg).
3. Requires system airflow, see thermal considerations.
4. J1 Mating plug: JST part no. PHR-2, contact: JST part no. SPH-002T-P0.5S.
5. J2 Mating plug: JST part no. PHDR-10VS, contact: 26-22 AWG JST part no. SPHD-001T-P0.5.

J1 Fan Connector (JST B2B-PH-KL (LF) (SN))	
Pin	Function
1	+V
2	NC
3	-V

J2 Logic Connector (JST B10B-PHDSS)	
Pin	Function
1	+ Sense
2	- Sense
3	AC OK/Power Fail
4	- Sense
5	Current Share
6	Current Share
7	+ Inhibit
8	- Inhibit
9	+5 V Standby (V3)
10	5 V Standby Return (V3)

Thermal Considerations (U Channel)

In order to ensure reliable operation in the end use application the recommended component temperatures listed should not be exceeded. Higher temperatures up to the maximum stated can be used but product lifetime may be reduced.

Temperature Measurements (Ambient ≤50 °C)		
Component	Recommended Temperature °C	Maximum Temperature °C
C55 Capacitor	70	105
T302 Transformer	90	120
C314 Capacitor	70	105
D311 Diode	100	120